

V A N T

A G E P

O I N T

2 0 0 6



Vantage Point Products Corp., P.O. Box 2485, Santa Fe Springs CA, 90670 USA
Tel: (562) 946-1718 | Fax: (562) 946-3898
www.vanptc.com



Mick & Don successfully delivered the first TV Hangers to the U.S. consumer market.

1987

Present



GLOBAL PACKAGING

Listening to our customers for the past 18 years has left us with the experience and knowledge that no other company can offer. Visit us online at vanptc.com to see how our solutions can help you.

 **VANTAGE™**
POINT
Possibilities are mounting.™

FLAT PANEL MOUNTING

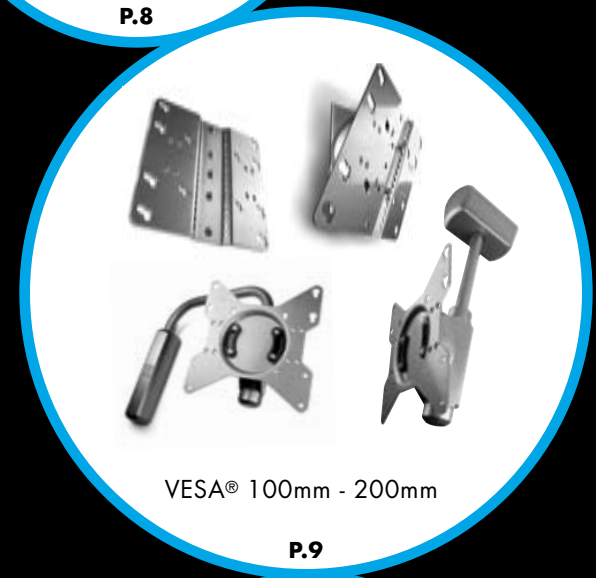
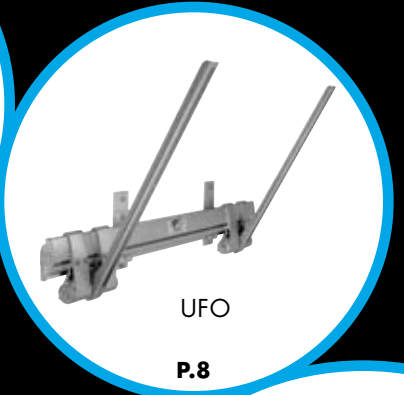

TELEVISION MOUNTING

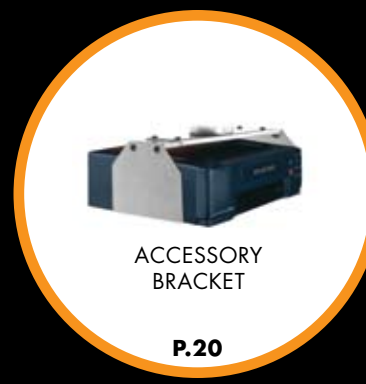

SPEAKER MOUNTING

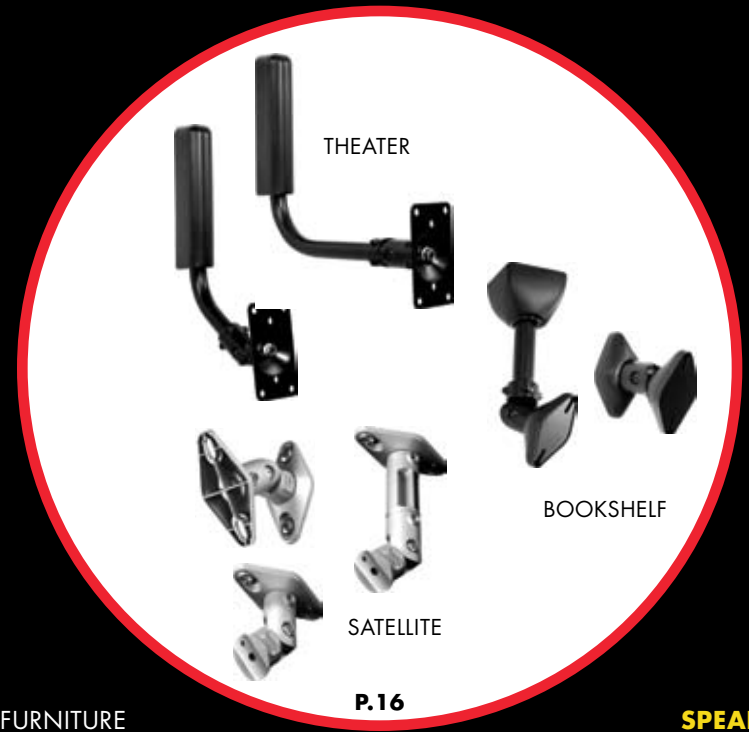

AUDIO/VIDEO FURNITURE



SPEAKER STANDS





A U70 FLAT PANEL MOUNT



B U50 FLAT PANEL MOUNT



UNIVERSAL FLAT PANEL MOUNT

UNIVERSAL FLAT PANEL MOUNT

The U50 and U70 flat panel mounts create a new standard when it comes to fit and finish for flat panel mounts. The slim design accompanied by the finished end caps along with the use of high-tech lightweight aluminum is both aesthetically pleasing and functionally rigid. Its open design eliminates worries of covering up wiring wall connections and provides a lightweight design that makes installation effortless. Clearly not the first flat panel mount in the market, but it could possibly be the last one you or your customer will ever use. Competitively priced, it packs the kind of valued features Vantage Point Products have become known for.



- UNIVERSAL LINE FEATURES**
- Screen tilts upward 2° and downward 15°
 - Shallow wall profile 2.63"
 - Easy Lock-In-Place feature to complete a secure installation
 - Easy side-to-side monitor positioning during installation
 - Sliding wall brackets accommodate any stud spacing

A U70 FLAT PANEL MOUNT

- U70 -B, -S
 MSRP
- Accommodates 43" - 70" plasmas
 - Supports up to 250 lbs.

B U50 FLAT PANEL MOUNT

- U50 -B, -S
 MSRP
- Accommodates 30" - 42" plasmas
 - Supports up to 200 lbs.

The UFO is designed to make installation of flat panel TV's and monitors a one person job. The lightweight aluminum rail is mounted to the wall, the brackets are mounted to the back of the monitor then the monitor simply hooks onto the horizontal rail. There is no need to pre-connect any wires since the UFO can be tilted forward far enough to enable access behind the monitor to completely detail the wiring and finalize the installation. The UFO then allows the monitor to be pushed back into the desired final position, flat or angled and secured for viewing. Truly in a class of its own; there is no substitution for the UFO.

UNIVERSAL FLAT PANEL MOUNT



UNIVERSAL LINE FEATURES

- Fits up to 50" flat panels
- 0° to 90° flip down allows for ease of wiring
- Sliding wall brackets accommodate any stud spacing
- Easy side-to-side monitor positioning during simple installation
- Maximum weight load 175 lbs. 

A UFO FLAT PANEL MOUNT

CGUFP01-S, -B
MSRP

 **VANTAGE™**
POINT
Possibilities are mounting.™

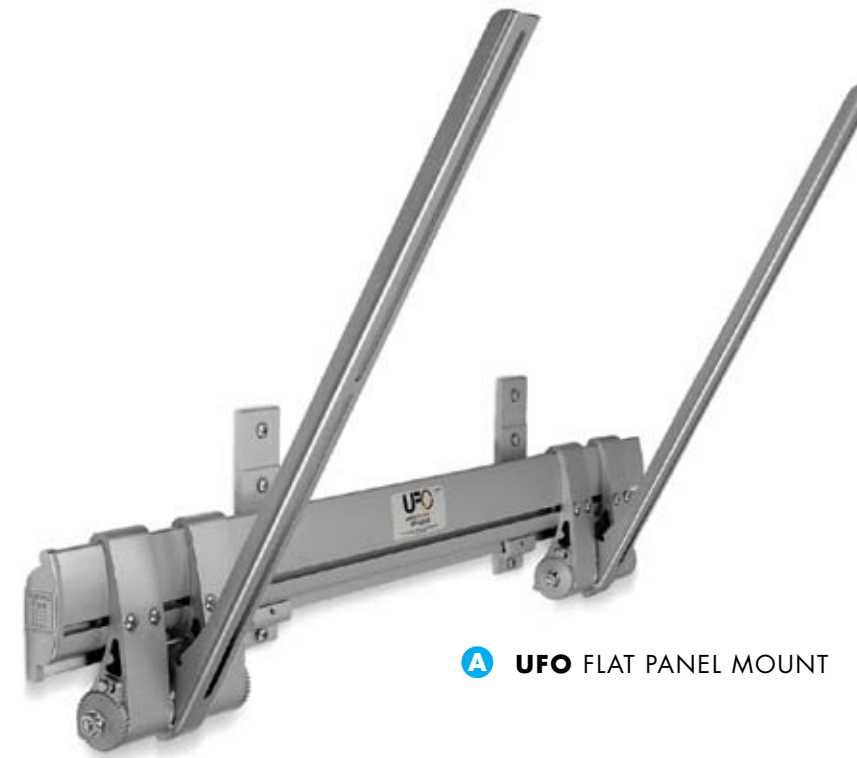

A UFO FLAT PANEL MOUNT



A UFO FLAT PANEL MOUNT

UNIVERSAL FLAT PANEL MOUNT

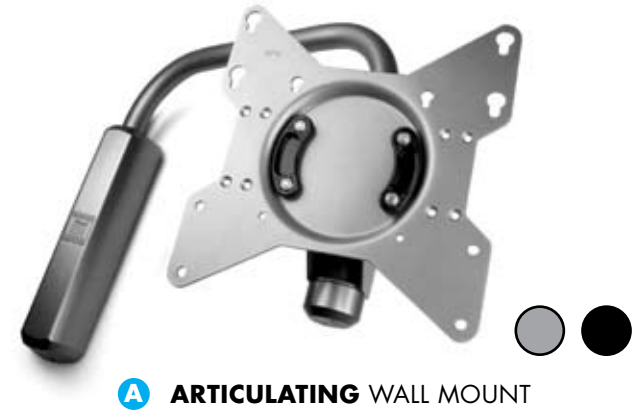

A **ARTICULATING WALL MOUNT**



C **FLAT WALL MOUNT**



B **CEILING MOUNT**



D **TILTING WALL MOUNT**



E **CENTER CHANNEL SPEAKER BRACKET**

UNIVERSAL FLAT PANEL MOUNTS

The VESA® 200mm line is designed to fit 100mm/200mm VESA® mounting patterns on LCD monitors that weigh up to 100 lbs. The line is engineered with a unique keyhole design which allows for easy installation. These mounts cover all the mounting possibilities for the emerging growth market of midsized LCD/flat panel monitors at price points that offer unsurpassed value.

UNIVERSAL FLAT PANEL MOUNTS



A **ARTICULATING WALL MOUNT**

AX2AWL01-B, -S
MSRP

- Tilts upward 5° and downward to 15°
- 3.75" retracted and 18.5" extension from the wall
- Up to 180° side to side viewing
- Unique de-rotation design provides ease of leveling monitor
- Articulates at wall and monitor
- Double stud version available (different SKU)

B **CEILING MOUNT**

AX2ACL01-B, -S
MSRP

- Tilts upward 5° and downward to 15°
- 15" drop from ceiling to center of LCD mount
- Up to 360° rotation or side to side viewing
- Unique de-rotation design provides ease of leveling monitor
- Double stud adapter plate available

C **FLAT WALL MOUNT**

AX2WL01-B, -S
MSRP

- .5" stand off from wall
- Fixed 5° spacer included for down angle viewing
- Easily installs to Component Shelf System (AXWG03)
- Double stud adapter plate available

D **TILTING WALL MOUNT**

AX2WL02-B, -S
MSRP

- Tilts upward 5° and downward to 15°
- 2.75" stand off from wall
- Easily installs to Component Shelf System (AXWG03)
- Double stud adaptor plate available

E **CENTER CHANNEL SPEAKER BRACKET**

AX2LSB01-B, -S
MSRP

- Fits most center channel speakers
- Compatible with all Vantage Point VESA® 200mm mounts
- Maximum weight load 15 lbs.

Consumers find Vantage Point universal LCD mounting systems are an easy buying decision because of the flexible design and the consumer friendly packaging. All mounts in the line are styled from steel and die-cast aluminum and are VESA® 75mm/100mm compliant. Competitively priced, these mounts will prove their value through years of reliable use as a result of the extra attention to large bearing areas and adjustable tension joints. A double stud adaptor is available for use with all mounts in the line to increase installation integrity and provide lateral positioning.

UNIVERSAL LCD MOUNTS



- A FIXED WALL MOUNT**
AXFL01-B, -S
MSRP
- Lies 1.14" away from wall when set at 0°
 - Features a 0° and a 7° downward angle setting
 - Maximum weight load 30 lbs.

- B TILT WALL MOUNT**
AXWL01-B, -S
MSRP
- Allows the monitor to be tilted up and down for precise viewing
 - Rotation at the wall plate enables a perfectly level monitor with every installation
 - Maximum weight load 40 lbs.

- C TILT, PAN WALL MOUNT**
AXWL02-B, -S
MSRP
- Combines all of the tilt and rotation features of the Tilt Wall Mount
 - Additional pan movement allows positioning from side to side
 - Maximum weight load 40 lbs.

- D TILT, PAN, EXTEND WALL MOUNT**
AXUL01-B, -S
MSRP
- Utilizes a single arm for increased tilting, panning and swiveling action
 - Advanced 4-axis positioning for optimum monitor flexibility
 - Rotation at the wall allows for perfect leveling
 - Mount can be situated on the ceiling, under a cabinet or on a desktop
 - Maximum weight load 40 lbs.

- E TILT, PAN, DOUBLE EXTEND WALL MOUNT**
AXUL02-B, -S
MSRP
- Uses a double articulating arm extending the range of pan movement for larger monitors
 - Double arm remains hidden when folded back against wall for the flattest appearance
 - Mount can be situated on the ceiling, under a cabinet or on a desktop
 - Maximum weight load 30 lbs.





A H SERIES SPEAKER STAND



B R SERIES SPEAKER STAND



C BOOKSHELF SPEAKER STAND

Vantage Point offers three lines of speaker stands beautifully designed with a stylish appearance and functional features to readily accommodate a wide variety of speakers and applications. All stands are engineered to be easy to assemble and include a hidden wire feature to control unsightly wires. In a category where function, simplicity and value are important, these products deliver. Minimal SKU's and a maximum range of function with non-competing styling make these stands an easy choice for a necessary yet simple category.

UNIVERSAL SPEAKER STANDS



A H SERIES SPEAKER STAND

- SSH40-SS, -BB
MSRP
- Riser adjusts up to 40" to maximize surround-sound quality
 - Accommodates speakers up to 8 lbs.
 - Curved riser keeps speakers centered for stability
 - Heavy duty cast iron base for stability
 - Universal mounting platform handles most satellite speakers

B R SERIES SPEAKER STAND

- SSR43-SS, -BB, -WW
MSRP
- Riser adjusts up to 43" to maximize surround-sound quality
 - Accommodates speakers up to 10 lbs.
 - 3-footed cast iron base ensures equal contact with floor and maximum stability
 - Universal platform and mounting hardware handle almost all satellite speakers

C BOOKSHELF SPEAKER STAND

- SSB30-S, -B
MSRP
- Uniquely adjust from 24"-30" using 1" spacers that hide from view
 - Accommodates speakers up to 25 lbs.
 - 3-footed cast iron base ensures equal contact with floor and maximum stability
 - Separate chamber to fill with sand/weighted material for greater performance
 - Universal mounting platform handles most bookshelf speakers

The Vantage Point Universal Speaker Mount line is designed with clean, simple styling to subtly offer versatility to wall and ceiling applications for various sized satellite, bookshelf and theater speakers. In the market for over 8 years, these speaker mounts continue to set the standard for function and value.

UNIVERSAL SPEAKER MOUNTS



A SATELLITE SPEAKER MOUNT

SINGLE: SATS-B, -S, -W
MSRP
PAIR: SATP-B, -S, -W
MSRP
5 PACK: SATS05-B, -S, -W
MSRP

- Supports speakers up to 8 lbs.
- Work perfectly with today's home theater surround-sound systems
- Compatible with most major brands of satellite speakers
- 4-axis, tilt and rotational adjustments for optimal positioning
- Extensions included for ceiling mount applications
- Key hole adapters included

B BOOKSHELF SPEAKER MOUNT

BKSP-S, -B, -W
MSRP
EXTENDED: BKSPE-S, -B, -W
MSRP

- Supports most mid-sized speakers up to 25 lbs.
- 4-axis, tilt and rotational adjustments for optimal positioning
- Available in an extended version for ceiling installations

C THEATER SPEAKER MOUNT

THRS-B, -W
MSRP
EXTENDED: THRSE-B, -W
MSRP

- Supports up to 50 lb. theater size speakers
- Full side to side positioning and over 180° of tilt adjustment
- Standard model is for back of speaker mounting
- Extended model is for under speaker mounting
- Both models can be used in an inverted application



A SATELLITE SPEAKER MOUNT

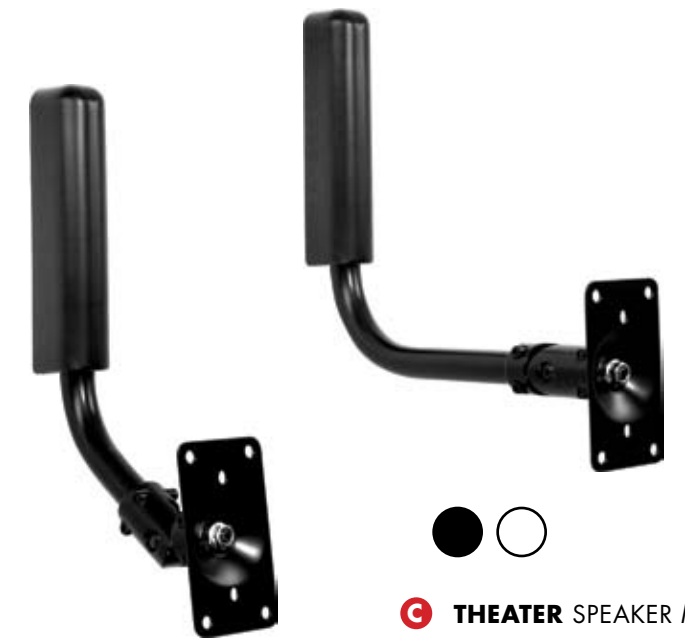

C THEATER SPEAKER MOUNT

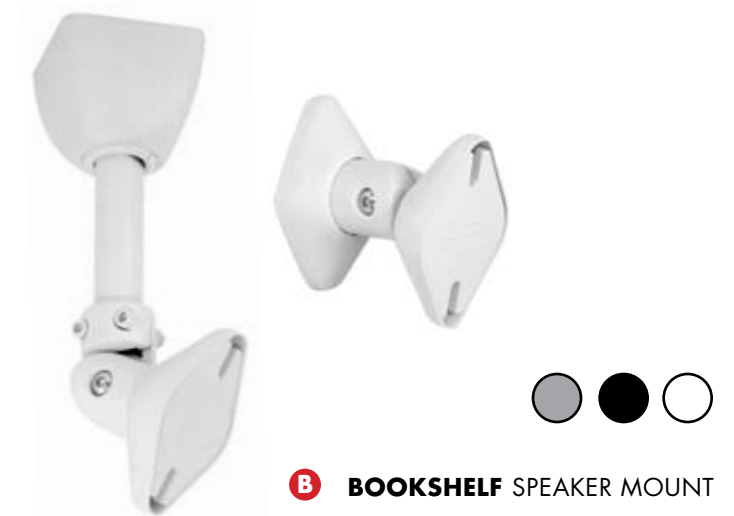

B BOOKSHELF SPEAKER MOUNT

UNIVERSAL SPEAKER MOUNTS



A 6" UNIVERSAL PROJECTOR MOUNT

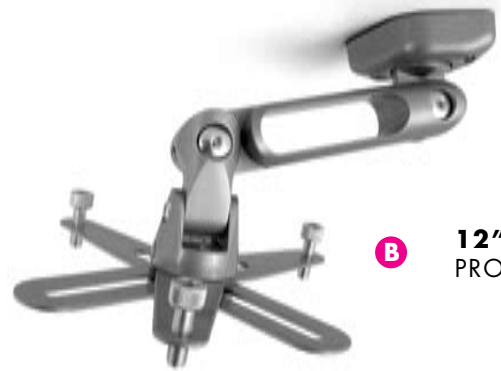

B 12" UNIVERSAL PROJECTOR MOUNT

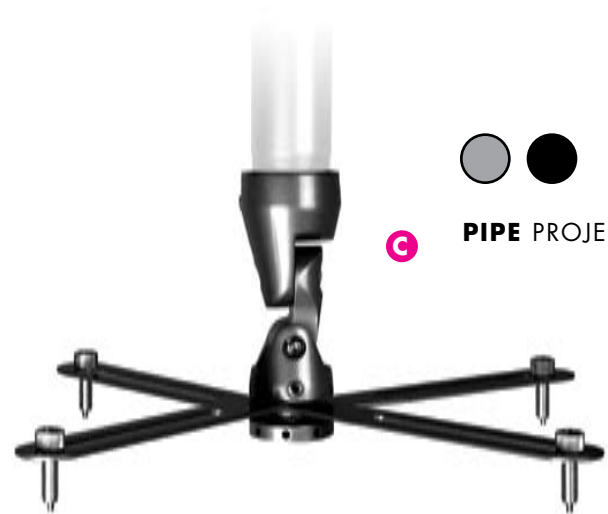

C PIPE PROJECTOR MOUNT

As the home theater revolution continues to grow, the purchase of a screen and projector become a viable solution for consumers to create a large viewing area. Our Universal Projector Mounts set themselves apart from other industrial looking projector mounts. Styled from steel and die-cast aluminum, the mounts boast a clean and simple finished appearance when viewed above the projector. The line is complete with 6" and 12" mounts for finished ceiling installations and a Pipe Projector Mount. The 6" and 12" projector mounts accommodate up to 30 lbs. and the Pipe Projector Mount accommodates up to 40 lbs. as the result of an additional support arm. Value engineered, these mounts are unmatched for quality and price in the market. A double stud adapter that can assist in positioning the projector is available for all finished ceiling mounts.

UNIVERSAL PROJECTOR MOUNTS



UNIVERSAL PROJECTOR MOUNTS

UNIVERSAL LINE FEATURES

- Compatible with most LCD or DLP projectors
- Fits mounting holes on bolt circles from 5.5" to 16"
- Simple roll, pitch and yaw adjustments
- Flat, vaulted and cathedral ceiling mountable
- Rotates, tilts and swivels in any direction

A 6" UNIVERSAL PROJECTOR MOUNT
 CGUPM06-S, -B
 MSRP

B 12" UNIVERSAL PROJECTOR MOUNT
 CGUPM12-S, -B
 MSRP

- 12" also offers up/down, left/right and forward/back projector movement and are wall mountable

C PIPE PROJECTOR MOUNT
 CGUPMPA-S, -B
 MSRP

- Attaches to 1.5" pipe (pipe not included)

While millions of conventional televisions remain in the market, consumer interest to find mounting solutions for these sets is continuing to grow as a result of the growth of flat panel mounting. The circumstance to sell these conventional mounts is greater than ever and provides an opportunity for consumers to enjoy the benefits of flat panel TV's at a fraction of the price. The clean designs of the Universal Television Mounts blend well with both residential and commercial applications for mounting on the wall and ceiling. All mounts include the necessary hardware for wood stud installations with a large safety strap to secure the television on the mount.

UNIVERSAL TELEVISION MOUNTS



A WALL MOUNT

PTW13-S, -B, -W
MSRP
PTW20-S, -B, -W
MSRP
PTW26-S, -B, -W
MSRP

- Designed for most wall mounting applications for 13" - 27" televisions
- Up to 180° side to side viewing
- The 13" - 20" mounts have adjustable tilt settings of 0°, 5°, 10° and hold up to 60 lbs.
- The 25" - 27" mounts have adjustable tilt settings of 0° and 7° and hold up to 80 lbs.

B CEILING MOUNT

PTC13-S, -B, -W
MSRP
PTC20-S, -B, -W
MSRP
PTC26-S, -B, -W
MSRP

- Designed for most finished ceiling mounting applications for 13" - 27" televisions
- Features 360° rotation for a wide range of viewing

C ACCESSORY BRACKET

PTVCR-S, -B, -W,
MSRP

- Designed to attach to both wall and ceiling TV mounts
- Accommodates components with a maximum height of 4.25" and width of 17.25"
- Rotates for perfect alignment with television

VANTAGE
POINT
Possibilities are mounting.™



C ACCESSORY BRACKET



UNIVERSAL TELEVISION MOUNTS



A COMPONENT SHELF SYSTEM



C AUDIO STAND



B SHELF ACCESSORY



D VIDEO STAND

For over 10 years, Vantage Point has been delivering audio /video furniture to customers looking for simple installation solutions to securely store their components with a versatility and style that complement their equipment and décor. The series is designed to be both functional and aesthetically pleasing to the eye. This quality furniture line perfectly blends these facets together. For safety all products are comprised of tempered glass. The component shelf system is the perfect complement to any on the wall video installation to provide a solution for supporting equipment. Frequently copied, the quality of Vantage Point furniture is unsurpassed and has stood the test of time.

FURNITURE



A COMPONENT SHELF SYSTEM

COMPONENT SHELF SYSTEM 3-SHELF
AXWG03-B, -S
MSRP

B COMPONENT SHELF ACCESSORY 1-SHELF
AXWG01-B, -S
MSRP

- Accommodates up to 25 lbs per shelf
- 160° rotation
- Adjustable shelves
- Hidden wire design
- LCD mount sold separately

C AUDIO STAND

VPAGG409-S
MSRP

- Shelves are 18" x 24"
- Overall height of 33" and 9" in between shelves
- Carpet piercing spikes are included for stability
- Optional accessories include spike pads, casters, and wire management kits

D VIDEO STAND

VPVGG309-S
MSRP

- Shelves are 18" x 45"
- Overall height of 22.5" and 9" between shelves